



DIGITAL MOTION DETECTOR MODULE MANUAL

DP-002A

GLOLAB
CORPORATION

Thank you for buying our DP-002A RoHS motion detector module

The goal of Glolab is to produce top quality electronic products and components. All of our products are designed by Glolab engineers and tested in our laboratory. Mechanical devices, prototypes and enclosures are fabricated in our precision machine shop.

Glolab Corporation has been in business since 1994 and has two locations in New York's Hudson Valley. Our electronics laboratory and packaging and our machine shop are located in Wappingers Falls.

Technical help is available by email from lab@glolab.com.

DP-002A applications

- **Wireless video camera activation**
-
- **Video recorder activation**

- **Automatic lighting**

- **General security devices**

- **Child or animal monitoring**

- **Talking messages**

- **OEM applications**

Copyright © 2009
Glolab Corporation
307 Pine Ridge Drive
Wappingers Falls, NY 12590

Introduction_____

This digital motion detector module is RoHS compliant and ready to use; just connect two or three 1.5 volt batteries or a three volt coin cell and an LED or piezo buzzer. Add a Fresnel lens for long-range detection up to 100 feet. View www.gloolab.com/focusdevices/focus.html.

The DP-002A digital pyroelectric infrared motion detector module is designed to detect infrared radiation (IR) from a moving human or animal both in daylight and at night. It will only respond to a moving source of infrared radiation; It will not detect a static IR source. The module includes a digital pyroelectric infrared sensor and a microprocessor to control the digital functions

User programming can be done for special applications that require different sensitivity, output on time (dwell) or operating mode. Programming is easy with external resistors.

Features_____

- **Very small size 0.35 X 0.5 X 0.7 inch**
 - **Good for OEM applications, RoHS**
- **Can be powered by 3 to 5 volts DC**
 - **Use a coin cell or AAA batteries**
- **Micropower circuit for low current drain**
 - **Average current 45 microamperes**
 - **Long battery life**
- **0 to VDD logic level output**
 - **Can source and sink 25 milliamperes**
- **Programmable sensitivity setting**
 - **Adjusts detection range**
- **Programmable dwell setting**
 - **Adjusts output ON time from 200 ms to 10 minutes**
- **Only three wire connections needed**
 - **Two for power - VDD, GND**
 - **One for output - OUT**

Digital Technology

The Glolab DP-002A uses a Digital infrared detector. This new technology incorporates a sensor, amplifier, filter, A/D converter in one TO5 package.

Unlike typical analog pyroelectric sensors, the digital sensor outputs serial data pulses that represent the amplitude of detected infrared radiation digital form. Since all of the amplification and signal processing is done within the sensor package, the detector has very high immunity to RF radiation from cell phones and other sources.

Figure 1 is a block diagram of the DP-002A. The processor decodes the serial bits from the sensor and turns an output on when motion is detected. The amount of time that the output remains on (dwell) can be programmed for one of ten dwell times from 200 milliseconds to 10 minutes. Detection sensitivity that affects detection range can be programmed to one of five sensitivity levels. The DP-002A is supplied with default settings of medium sensitivity and 1 second dwell time.

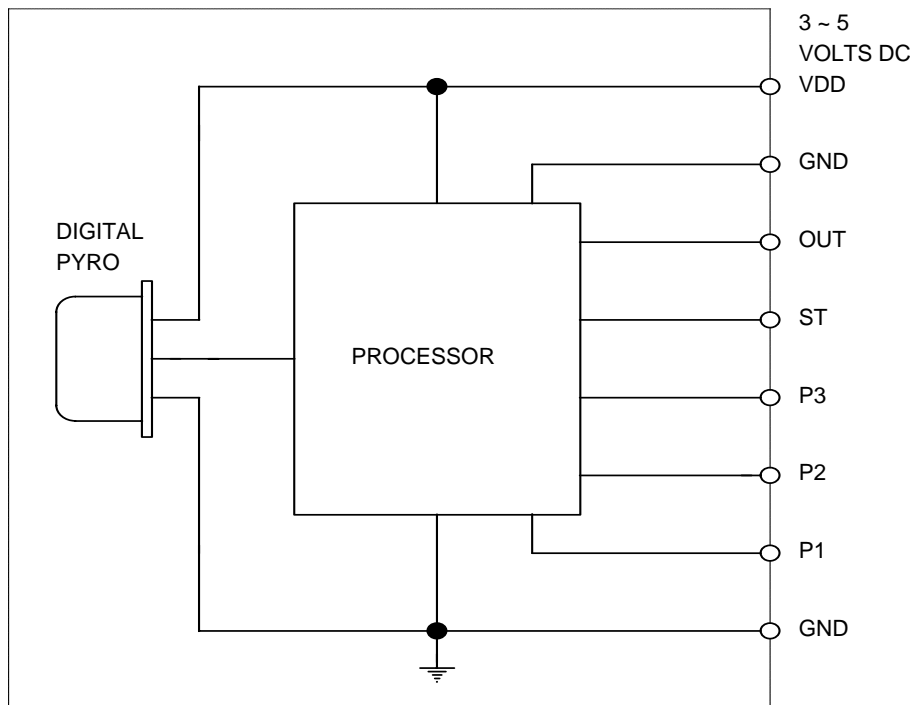

Figure 1

Note:

Absolute maximum ratings are values beyond which permanent damage to the module might result. The DP-002A does not have internal reversed polarity protection so care must be taken not to apply reversed polarity voltage to the VDD and GND pads.

ABSOLUTE MAXIMUM RATINGS

PARAMETER	RATING	UNITS
Power supply voltage ¹	5.25	Volts
Logic output source current ²	25	Milliamperes
Logic output sink current ²	25	Milliamperes

Notes:

1. Voltage from VDD to GND power terminals on PC board
2. External load on output

TYPICAL OPERATION

PARAMETER	MIN	TYPICAL	MAX	UNITS
Power supply voltage ³	3.0	3.0	5.0	Volts
Circuit current ⁴	-	45	-	Microamperes
Logic output source current ⁵	-	-	25	Milliamperes
Logic output sink current ⁵	-	-	25	Milliamperes
Operating temperature	-40°C	-	+85°C	

Notes:

3. Voltage from VDD to GND power terminals on PC board
4. When output is at 0 volts
5. External load on output

Ordering information _____

PART NUMBER	DESCRIPTION
DP-002A	Digital motion detector module RoHS

Description

The DP-002A is 0.35 inch (8.9mm) deep, 0.5 inch (12.7mm) wide, and 0.7 inch (17.8mm) long. Components are on the front side of the PC board and the sensor and pad labeling are on the back side. The module should be mounted with the connection pads on sides for best sensitivity to horizontal motion. Solder pads for VDD, GND, OUT are provided on one edge of the module to connect power and output wires. Sensitivity, mode and dwell are programmed by temporary connections to programming pads on the other edge. Programming instructions are on page 7.

Sensitivity

Sensitivity and therefore range (detection distance) can be programmed for one of five levels. Sensitivity default is set to medium.

Dwell

Dwell time or the amount of time the output remains ON after motion is detected can be programmed for one of ten dwell times from 200 milliseconds to 10 minutes. The default dwell is set at 1 second.

Mode

Retriggerable mode will reset the dwell timer to zero whenever more motion is detected during dwell timeout. This will cause the output to remain ON for an additional dwell period. Retriggering will continue and the output will remain ON as long as motion is detected before the dwell timeout expires. The default mode is set as Retriggerable. The 200 millisecond dwell time will not retrigger even if retriggerable mode is programmed.

Single event mode will inhibit multiple outputs from occurring in rapid succession. The output will turn ON when motion is detected and will stay ON for only the dwell timeout. The output will then turn OFF and remain OFF until no more motion is detected before responding to another motion event. This mode is somewhat similar to an inverted version of retriggerable mode.

Outputs

The DP-002A output is directly from a microprocessor that is capable of sourcing and sinking up to 25 milliamperes. The output voltage level will be at 0 volts when no motion is detected will go to + Vdd when motion is detected. The output can directly drive a light emitting diode, piezo buzzer and logic or microprocessor circuits.

Power

3 to 5 volts will power the DP-002A at a current of 45 microamperes when no motion is detected. An AC mains power source should be filtered and regulated, however the DP-002A can be powered directly from a battery such as a 3 volt coin cell or from two or three 1.5 volt AAA cells. The DP-002A is not reverse polarity protected so care must be taken not to apply a reversed polarity power connection. A battery holder that prevents incorrect insertion is recommended if batteries power the module.

Programming resistors _____

Programming of sensitivity, dwell time and output mode is done by temporarily connecting P1 and P2 to ground and an external resistor from P3 to ground as shown in the tables on page 7, and then grounding the store pad ST for one second. Sensitivity programming needs only a resistor from P3 to ground while other program functions also need P1 or P2, or both P1 and P2 grounded.

A programmed function is stored in non-volatile memory when the store pad ST is grounded for one second and then opened. A programmed function will not change until re-programmed and will not be lost when power is removed from the module. Sensitivity, output mode and dwell time programming are independent of each other and must be individually programmed.

The programming resistor can be any size or wattage and can have a 5% resistance tolerance. Ground connections should be removed from P1, P2 and the resistor from P3 after programming has been completed.

Sensitivity, Dwell and Mode are all simultaneously reset to defaults by grounding P1, P2 and P3 and then grounding ST for one second. This is useful as a quick way to return to defaults when existing programming is unknown.

Programming sensitivity, mode and dwell

One of five sensitivity levels, one of ten dwell times and one of two output modes can be programmed. Follow the steps below for table 1 to program sensitivity. Repeat the steps below for table 2 to program dwell time and for table 3 to program mode. A power source must be connected before programming. Ground (GND) is the $-V$ terminal.70

1. Leave P1, P2 open or connect to ground (GND) as shown in the table
2. Connect a resistor of the value shown in the table to P3 and to ground
3. Ground ST for 1 second (stores data in memory)
4. Remove ground and resistor from P1, P2, P3

TABLE 1 SENSITIVITY LEVEL	P1	P2	P3	ST
MINIMUM	OPEN	OPEN	2.7 KOHMS TO GND	GND-OPEN
LOW	OPEN	OPEN	6.8 KOHMS TO GND	GND-OPEN
MEDIUM (DEFAULT)	OPEN	OPEN	GND	GND-OPEN
HIGH	OPEN	OPEN	15 KOHMS TO GND	GND-OPEN
MAXIMUM	OPEN	OPEN	39 KOHMS TO GND	GND-OPEN

TABLE 2 DWELL TIME	P1	P2	P3	ST
0.2 SECOND	GND	OPEN	2.7 KOHMS TO GND	GND-OPEN
1 SECOND (DEFAULT)	GND	OPEN	GND	GND-OPEN
2 SECOND	GND	OPEN	6.8 KOHMS TO GND	GND-OPEN
5 SECOND	GND	OPEN	15 KOHMS TO GND	GND-OPEN
10 SECOND	GND	OPEN	39 KOHMS TO GND	GND-OPEN
30 SECOND	OPEN	GND	GND	GND-OPEN
1 MINUTE	OPEN	GND	2.7 KOHMS TO GND	GND-OPEN
2 MINUTE	OPEN	GND	6.8 KOHMS TO GND	GND-OPEN
5 MINUTE	OPEN	GND	15 KOHMS TO GND	GND-OPEN
10 MINUTE	OPEN	GND	39 KOHMS TO GND	GND-OPEN

TABLE 3 MODE	P1	P2	P3	ST
RETRIGGERABLE (DEFAULT)	GND	GND	2.7 KOHMS TO GND	GND-OPEN
SINGLE PULSE	GND	GND	6.8 KOHMS TO GND	GND-OPEN
RESTORE ALL DEFAULTS	GND	GND	GND	GND-OPEN

Power, output and programming pads

The DP-002A should be mounted with its connection pads at the sides. This positions the sensor elements for best sensitivity to horizontal motion.

Power and output connections are made to the solder pads on the left edge of the module when looking at figure 2. Programming pads are on the right side of the module. This is a component side view. The sensor is mounted on the back side of the PC board.

Pads are spaced 0.1 inch apart. Left and right rows of pads are spaced 0.6 inch apart. Standard pin headers with 0.025 inch square pins on 0.1 inch centers will fit in the pad holes.

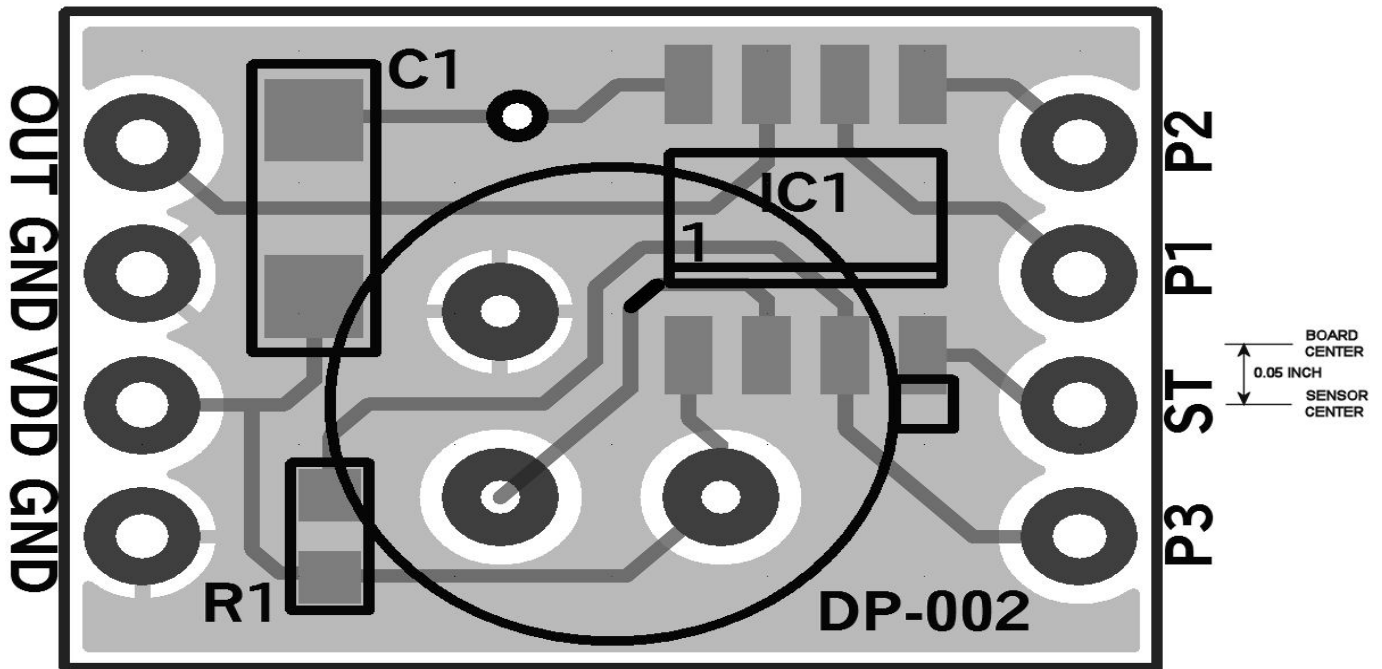

FIGURE 2 COMPONENT SIDE VIEW

Installation

The DP-002A has two rows of four 0.035 inch diameter pad holes on 0.1 inch centers spaced 0.6 inch apart on the left and right edge of the module. Wires can be inserted and soldered into the pad holes or two four pin headers with 0.025 inch square pins on 0.1 inch centers can be soldered onto the holes from either the top or bottom side of the module. The pin headers can then be plugged into inline sockets that serves as both a mount for the module and as connections for power, output and programming. If the pin headers are inserted from the top side of the module the other end of the headers can be soldered directly into pad holes on a printed circuit board. Lead free solder should be used when soldering to the pads if RoHS compliance is necessary.

The DP-002A module can be housed in an enclosure that has a hole machined for a Fresnel lens. The DP-002A should be positioned with its connector pads on the sides for best detection of horizontal motion and the front of the sensor should be the correct distance from the lens, depending on the focal length of the lens. Power and output can be through a minimum of three connections; two for power and one for output.

Testing

The DP-002A is default programmed for retriggerable output and 1 second dwell. Connect a power source to the PC board power pads VDD and GND. Connect the anode lead of a light emitting diode in series with a 510 ohm resistor to the output pad OUT and connect the cathode lead of the light emitting diode to the power source negative, GND. The LED will light when motion is sensed. Allow at least 15 seconds for the circuits to stabilize after applying power. The sensor will detect a hand moving toward either side of center at a distance of about eight inches without a lens and with sensitivity at medium (default).

A lens or other focusing scheme must be used for long range detection. You can find information about focusing devices at www.glolab.com/focusdevices/focus.html.

The PIR sensor is sensitive to fast temperature changes especially at high sensitivity settings and will produce multiple outputs after it is touched or otherwise exposed to heat or cold. It should be protected from warm or cold air movement from an air conditioner, heating system, open window or other moving air sources when not covered by an enclosure. The sensor will stabilize in about one minute after the source of temperature change has been removed.

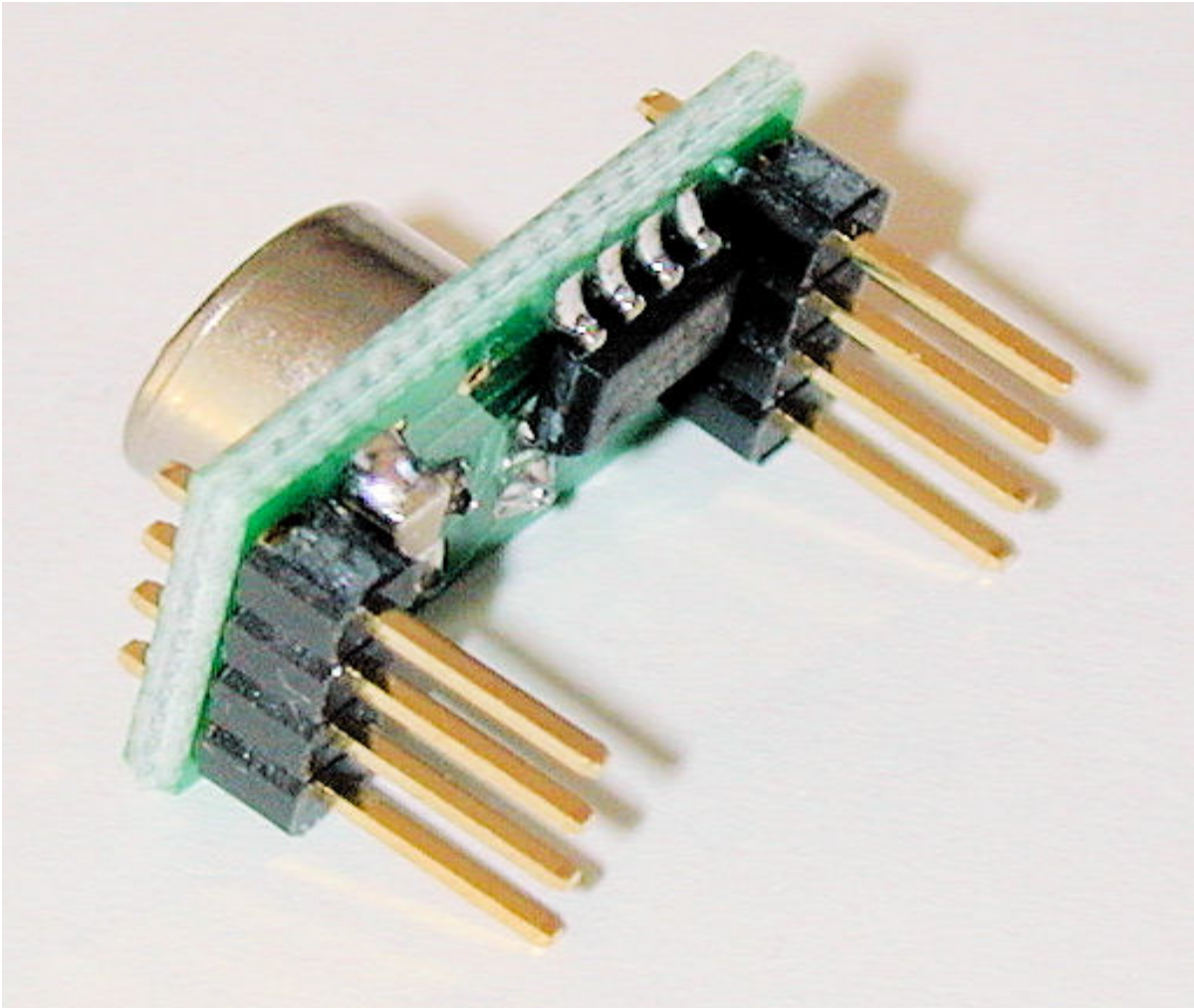

DP-002A WITH OPTIONAL PIN HEADERS



GLOLAB
CORPORATION

307 Pine Ridge Drive
Wappingers Falls, NY 12590
voice - (845) 297-9771
Fax - (845) 297-9772
Email - lab@glolab.com
<http://www.glolab.com>
© 2009 Glolab Corp.