



WIRELESS MODULE MANUAL

TM1V RM2

GLOLAB
CORPORATION

Thank you for buying our Wireless Modules.

The goal of Glolab is to produce top quality electronic kits, products and components. All of our products are designed by Glolab engineers and tested in our laboratory. Mechanical devices, prototypes and enclosures are fabricated in our precision machine shop.

Glolab Corporation has two locations in New York's Hudson Valley. Both our electronics laboratory and machine shop are located in Wappingers Falls.

Technical help is available by email from lab@glolab.com.

NOTICE:

THESE MODULES ARE NOT FCC CERTIFIED. IF THEY ARE USED IN A PRODUCT, THAT PRODUCT MUST BE SENT TO A TESTING LABORATORY AND SUBMITTED FOR FCC CERTIFICATION BEFORE IT CAN BE SOLD

Copyright © 2007
Glolab Corporation
307 Pine Ridge Drive
Wappingers Falls, NY 12590

Introduction_____

Today wireless is used almost everywhere for almost everything. Devices are available to send audio, video, security data, computer data, to open garage doors and turn on lights. However, for a specific control or pulse application not covered by one of these available devices you usually have to build your own. In the past, building a simple and reliable transmitter and sensitive receiver was not easy. And after building them some difficult adjustments and measurements would have to be made to set operating frequency, minimize transmitter harmonic radiation and maximize receiver sensitivity.

But now, thanks to new TM1V and RM2 modules from Glolab, all of those problems are things of the past. You simply apply power to the modules that are SAW (Surface Acoustic Wave) based for accurate frequency control and attach 6.7 inch whip antennas to transmit and receive data. Absolutely no adjustments of any kind are required and no sensitive RF components are exposed.

These modules are for on-off and pulse applications at data rates up to 4,800 bps. They will not transmit or receive audio, video or any linear-amplitude or frequency modulated signals. They operate at 418 Mhz and are designed for use as unlicensed transmitters operating under FCC Part 15. These modules cannot be used in a product unless that product is first submitted to a testing laboratory and then certified by the Federal Communications Commission.

The High Sensitivity RM2 receiver module has a long reception range, however, its very high sensitivity results in random pulse output when no signal is being received. The random pulses can interfere with the operation of some decoders and must be considered for each application of the RM2. The Glolab GL-104 encoder/decoder is recommended for use with the RM2 module.

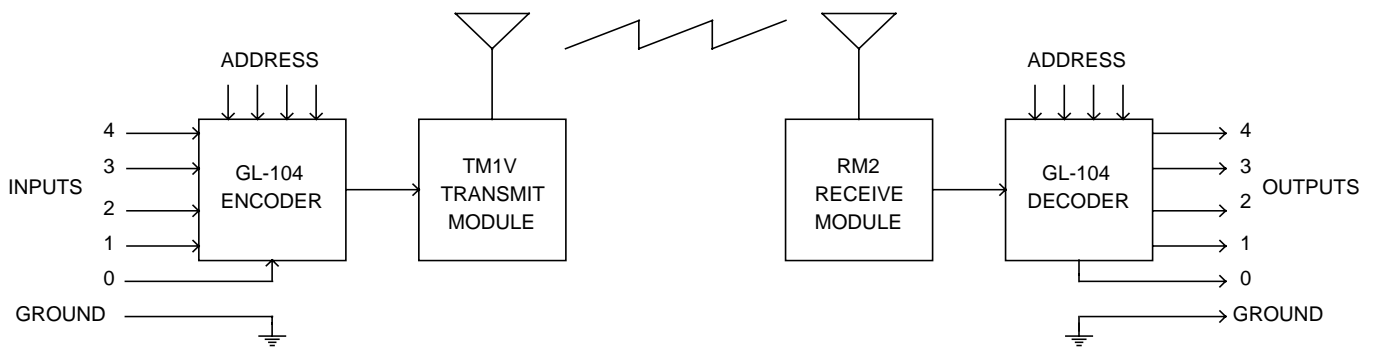

Block diagram of typical wireless remote control

Transmitter _____

Power supply

The TM1V transmitter requires a clean, well regulated power source. While it is preferable to power the unit from a battery, the unit can also be operated from a power supply as long as noise and hash are kept to less than 20mv. A VR5L 5 volt low dropout micropower regulator is excellent for use with a 6 or 9 volt battery.

Parameter	pin	Min	Typical	Max	Units
Operating voltage range	4	2.7	-	5.2	volts
Supply current		2.0	3.0	6.0	ma
Average supply current (50% on)		-	1.5	-	ma
Standby current (logic low)		-		1.5	µa
Transmit frequency		417.96	418.02	418.08	Mhz
Expected output load	2	-	50	-	ohms
Data input level Logic low	5	0	-	0.4	vdc
Data input level Logic high	5	2.5	-	Vcc	vdc
Data rate	5	300	-	5,000	bits/sec
Oscillator start-up time		-	-	80	µs

Absolute maximum ratings:			
Supply voltage Vcc	-0.3	to	+6 vdc
Operating temperature	0°C	to	+70°C
Storage temperature	-45°C	to	+85°C
Any input or output pin	-0.3	to	Vcc

Description

The TM1V is a low cost, high performance SAW (Surface Acoustic Wave) based CW (Continuous Wave) transmitter capable of sending serial data at up to 4,800 bits/second. The TM1's ultra low power consumption (1.5 ma typ.) makes it ideally suited for projects powered from a battery. When combined with a RM1V receiver, a highly reliable RF link capable of transferring digital data over line-of-sight distances in excess of 300 feet (90M) is formed.

Operation

The TM1V transmits data using the CW method in which a logic low '0' is represented by the absence of a carrier and a logic high '1' by the presence of a carrier. This method offers design simplicity, low average power consumption, and near zero power consumption during standby. The transmitter is very stable over time, temperature, and physical shock as a result of the precision SAW (Surface Acoustic Wave) device that is incorporated as its frequency reference. Due to this accuracy and the high Q of the SAW device most of the output power is concentrated in a narrow bandwidth. This allows the receiver's pass opening to be quite narrow, thus increasing sensitivity and reducing susceptibility to near-band interference.

Pin descriptions:		
1	Ground	Connect to ground plane
2	RF out	Connect to 50 ohm antenna
3	Ground	Connect to ground plane
4	Vcc	Positive supply 2.7 to 5.2 vdc ($\leq 20\text{mv pp noise}$)
5	Data	Serial data input pin CMOS and TTL compatible
6	Ground	Connect to ground plane

TM1V transmit module outline drawings and pin numbers

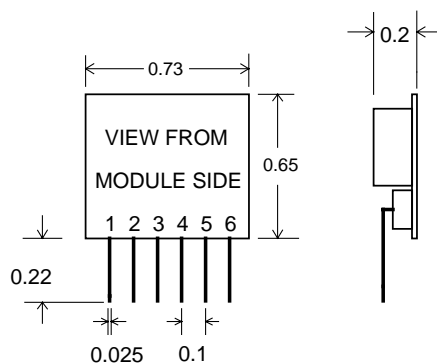

PIN	DESCRIPTION
1	GROUND
2	RF OUT
3	GROUND
4	VCC
5	DATA IN
6	GROUND

RM2 Receiver module _____

Power supply

The RM2 receivers requires a clean, well regulated power source with less than 20mv of noise and hash.

Parameter	pin	Min	Typical	Max	Units	Notes
Operating voltage range (Vcc)	3	4.0	-	5.2	volts	
Power down	2	0	0	Vcc	volts	1,2
Supply current		6.0	7.0	8	ma	
Receive frequency		-	418	-	Mhz	-
Receive frequency		417.96	418.02	418.08	MHz	-
Noise bandwidth		-	280	-	KHz	-
RF input impedance	6	-	50	-	ohms	-
Data output level Logic low	4	0	0.22	-	vdc	3,4
Data output level Logic high	4	-	-	Vcc	vdc	3,4
Data rate	4	300	-	4,800	bits/sec	-
Initial settling time (on power up)	4	1	-	3	ms	3
Settling time	4	5	7	10	ms	3

Notes:

1. connect to ground for power down, float or Vcc for power up.
2. Power down current = 30 microamperes.
3. With 24 milliampere load
4. Output can source and sink 24 milliamperes.
5. Time to valid data output.

Absolute maximum ratings:			
Supply voltage Vcc	-0.3	to	+6.0 vdc
Operating temperature	0°C	to	+70°C
Storage temperature	-45°C	to	+85°C
Any input or output pin	-0.3	to	Vcc

Description

The RM2 is a low cost, high performance SAW (Surface Acoustic Wave) based CW (Continuous Wave) receivers capable of receiving serial data at up to 4,800 bits/second. The exceptional sensitivity provides outstanding range at the maximum data rate. When combined with a TM1V transmitter, a highly reliable RF link capable of transferring digital data over line-of-sight distances in excess of 300 feet (90M) is formed. The high sensitivity RM2 receiver module

can receive serial data at line-of-sight distances of up to 3000 feet (900M), more than one half mile.

Operation

The RM2 is designed to recover data using the CW method in which a logic low ‘0’ is represented by the absence of a carrier and a logic high ‘1’ by the presence of a carrier. The receivers utilize an advanced single-conversion superhet design which incorporates a SAW device, high IF frequency and multi-layer ceramic filters. The SAW (Surface Acoustic Wave) device has been in use for more than a decade but has only recently begun to receive the widespread acclaim its outstanding capabilities deserve. A SAW device provides a highly accurate frequency source with excellent immunity to frequency shift due to age or temperature. The use of SAW devices allows the receiver’s pass opening to be quite narrow, thus increasing sensitivity and reducing susceptibility to near-band interference. The quality of components and overall architecture utilized is highly unusual in a low-cost RF device and is one of the primary reasons the RM1V is able to outperform even far more expensive products.

RM1V and RM2 Pin descriptions:		
1	Ground	Connect to ground plane
2	PDN	Connect to ground to power down, leave floating to power up.
3	Vcc	Power supply input 2.7 to 5.5 vdc
4	Data out	Recovered data, voltage during high bit = Vcc
5	Ground	Connect to ground plane
6	RF in	Receiver antenna input. Capacitively isolated from circuit.
7	Ground	Connect to ground plane

RM2 receive module outline drawings and pin numbers

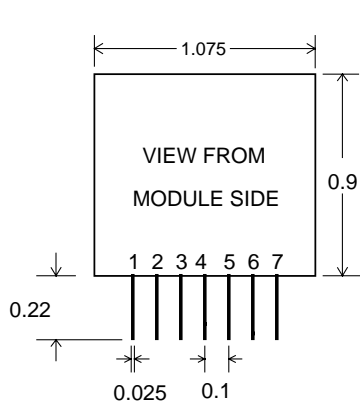

PIN	DESCRIPTION
1	GROUND
2	POWER DOWN
3	VCC (2.7 - 5.5)
4	DATA OUT
5	GROUND
6	RF IN
7	GROUND

Input and Output _____

Transmitter Data input

A CMOS/TTL level data input is provided on pin 5. This pin is normally supplied with a serial bit stream input directly from a microprocessor, encoder, or UART. During standby or the input of a logic low, the carrier is fully suppressed and the transmitter consumes less than 2 μ a of current. During a logic high the transmitter generates a carrier to indicate to the receiver the presence of a logic 1. The applied data should change state at a rate of at least 300 bits/second and should not exceed a rate of 4,800 bits/sec. The data input pin should always be driven with a voltage common to the supply voltage present at pin 4 (Vcc). Under no condition should the data pin be allowed to exceed the supply voltage (Vcc).

Generating data

The TM1V modules do not incorporate internal encoding. If you want to send simple control or status signals such as button presses or switch closures, consider using an encoder and decoder IC set that takes care of all encoding, error checking, and decoding functions. They are an excellent way to implement basic remote control. A Microchip Technology PIC microprocessor can also be used to encode and serialize data.

Receiver Data output

A 0 volt to Vcc data output is available on pin 4 of the RM2. This output is normally used to drive a digital decoder IC or a microprocessor which is performing the data decoding. The RM2 receiver's output will produce random pulses that transition high when no valid data is present. A decoder or microprocessor that is designed to ignore these random pulses must be used with a RM2 receiver module.

Decoding data

The RM2 module does not incorporate internal decoding. If you want to receive simple control or status signals such as button presses or switch closures, you can use the encoder and decoder IC set described above. Decoders with momentary and latched outputs are available. A PIC microprocessor can also be used for de-serializing and decoding.

Transmitting and Receiving

Full duplex or simultaneous two-way operation is not possible with these modules. If a transmit and receive module are in close proximity and data is sent to a remote receive module while attempting to simultaneously receive data from a remote transmit module, the receiver will be overloaded by its close proximity transmitter. This will happen even if encoders and decoders are used with different address settings for each transmitter and receiver pair. If two way communication is required, only half duplex operation is allowed.

Layout

A few layout principles and basic design rules should be followed to insure good operation and performance.

1. No conductive items should be placed within .15 inches of the module top or sides.
2. Observe appropriate RF layout practice between the module and its antenna. A simple trace is suitable for runs up to 1 inch but longer distances should be covered using 50 ohm coax.
3. A ground plane or wide ground traces should be used near the module.
4. Keep receiver module away from interference sources. Any frequency of sufficient amplitude to enter the receiver's front end will reduce system range, cause bit errors, and may even prevent reception entirely. High speed logic is one of the worst sources of internally generated interference. Single-chip microprocessors do not generally pose an interference problem.

Antenna

The following should help in achieving optimum antenna performance:

1. Proximity to objects such as a user's hand or body, or metal objects will cause an antenna to detune. For this reason the antenna shaft and tip should be positioned as far away from such objects as possible.
2. Optimum performance will be obtained from a 1/4 or 1/2 wave straight whip mounted at a right angle to the ground plane. A 1/4 wave antenna for 418 Mhz is 6.7 inches long.
3. In many antenna designs, particularly 1/4 wave whips, the ground plane acts as a counterpoise, forming in essence, a 1/2 wave dipole. Adequate ground plane area will give maximum performance. As a general rule the ground plane to be used as counterpoise should have a surface area => the overall length of the 1/4 wave radiating element (2.6 X 2.6 inches for a 6.7 inch long antenna).
4. Remove the antenna as far as possible from potential interference sources. Place adequate ground plane under all potential sources of noise.
5. In some applications it is advantageous to place the transmitter or receiver and its antenna away from the main equipment. Always use 50 ohm coax for a remote feed.

Encoder and decoder applications _____

The radio frequency spectrum is filled with noise and other signals, especially those frequencies where unlicensed transmitter operation under FCC part 15 rules is allowed. When using a wireless remote control system it is desirable to have a way of filtering out or ignoring those unwanted signals to prevent false data from being received. A simple way to accomplish this is to use an encoder IC at the transmitter and a decoder IC at the receiver. The encoder generates serial codes that are typically automatically sent three times and must be received at least twice before data is accepted as valid by the decoder circuit.

In the early days of "radio control", before these coding ICs were available, radio controlled garage doors sometimes opened themselves when they received transmissions from a plane passing overhead or a two-way radio operating in the area. Encoding and decoding is now used in most wireless control systems to prevent this type of interference.

A GL-104 IC in an 18 pin DIP package available from Glolab can be used as either an encoder or decoder just by changing the connection to one pin. These devices also offer more flexibility than the usual encoder and decoder ICs. The GL-104 will be used in the following application examples. These devices have four data channels and sixteen selectable addresses. Download specs at <http://www.glolab.com/encdec/gl-104.html>.

Active low push button transmitter

Figure 1 is a complete push button transmitter that operates in the input active low mode which means that the circuit becomes active and transmits data when any data input is connected low (Vss) by a push button switch, a logic circuit or any other device. Internal 200 microampere current sources pull the input pins high when the switches are open. When all inputs are high, the encoder goes into a standby mode and draws only 1 microampere.

The circuit operates from a 9 volt battery through a 5 volt low dropout micropower regulator and uses only 3 microamperes of current when no buttons are being pressed. This design needs only one capacitor. Address selection pins 1-2, 17-18 connect to Vss through resistors R1-R4 which connect to pulldown pin 3. This pin pulls down to Vss only when the encoder is active so the pulldowns do not draw current during standby. The address pins can be connected to Vdd through DIP switches for address selection.

Addressing is used to give a unique identity to one pair of encoded devices such as an RF transmitter and receiver and to distinguish that pair from another that has its address pins connected for a different address. This allows a transmission from a transmitter/receiver pair to be received only by its own receiver. Also, by changing addresses, the transmitter can send to a different receiver that matches its new address.

A low level on transmitter input 0 will activate the valid data pin in a receiver. See figure 2 for a

Momentary or latched output receiver

Figure 2 is a complete receiver with outputs that can be either momentary or latched. R5 pulls control pin 12 high. When DIP switch 5 is closed pin 12 is pulled low and the outputs become momentary. When switch 5 is open the outputs will latch the received data until new data is received or until reset by connecting the reset terminal low.

The decoder outputs drive status LEDs and IRL510 power FETs in TO220 packages that can sink 5 amperes to power relays or loads directly. Higher power FETs may be used for heavier loads if desired.

The momentary function can be used with the transmitter in figure 1 for wireless control of machinery or any device that has to be energized while a remote control button or buttons are being pressed. Valid data pin 6 will go high whenever any data is being received. Data outputs 0-3 may be energized either individually or simultaneously.

Address switches 1-4 should be set the same as in the transmitter.

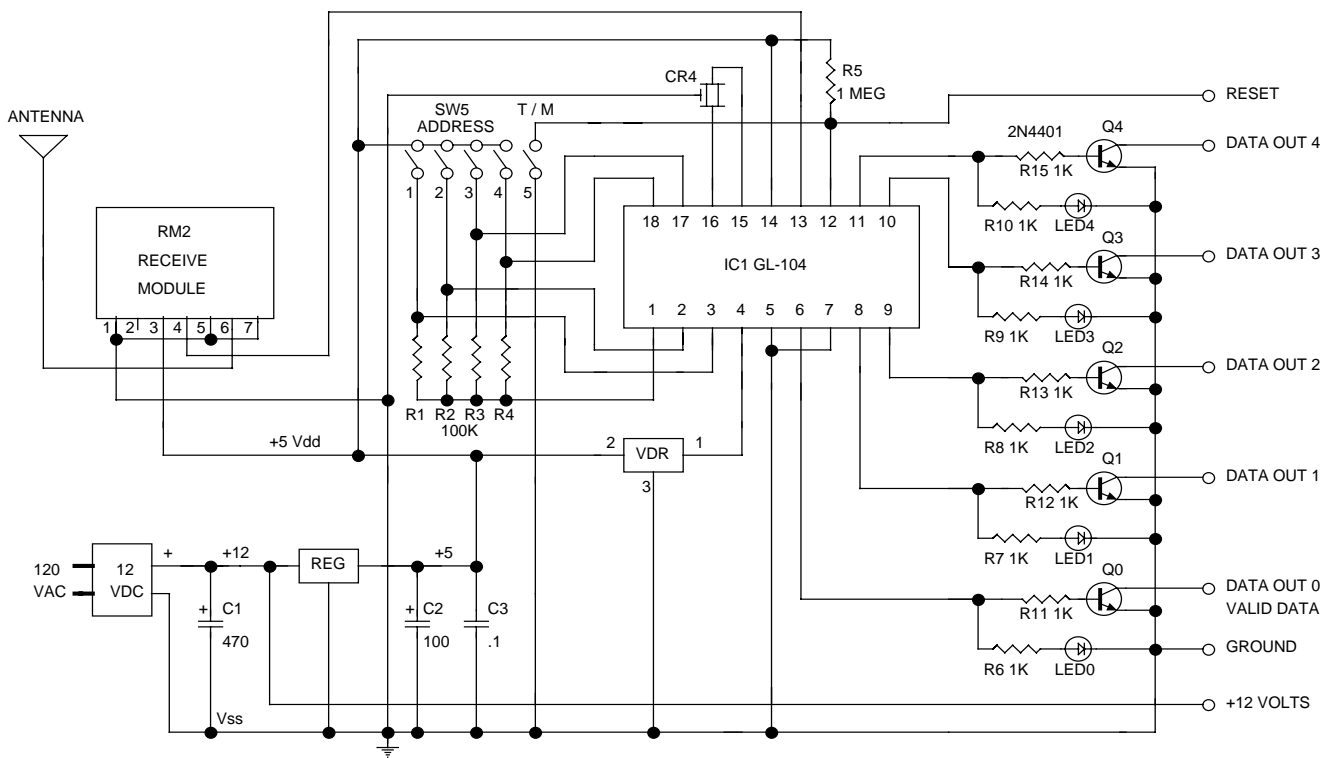

FIGURE 2

These encoder/decoder devices do not provide error correction. They just accept valid data and reject corrupted data. This means that a control signal that is corrupted will not be received and must be sent again.

Antennas _____

We have three types of antennas for use with our RF modules. Although our TM1V, RM1V and RM2 modules can be used with an antenna made of almost any piece of wire of appropriate length for the frequency, some of these optional antennas may be better suited for your application. The transmitting and receiving antennas do not have to be of the same type. For example, a helical antenna can be used on the transmitter and a whip on the receiver. For best performance, the whip antennas should be mounted on a ground plane having an area of 6.7 square inches or larger. (example 2.3" X 3")

Wire whip

The WC418 is made of 26 gauge carbon steel music wire that can be soldered to a PC board. This antenna has a plastic coated tip for safety and is 6.8 inches long, allowing .1 inch for insertion in a terminal or PC board.

Weatherproof whip

The WA418 is a flexible, plastic covered weatherproof 1/4 wavelength antenna for 418 MHz. It is mounted by a brass 1/4-20 threaded stud and is supplied with a brass mounting nut. This antenna has an 7 inch long 50 ohm coaxial cable that may be cut to any desired length.

Helical loop

The HT418 is a 418 MHz helical antenna designed for through hole mounting on a PC board. It is 3/8 inch diameter and 1.5 inches long. This antenna is like a coiled up whip and is therefore less efficient than a straight whip but is useful in a compact device such as a handheld transmitter. One end connects to the transmitter or receiver antenna pin and the other end is open. It can be soldered to a floating PC board pad for mechanical strength.

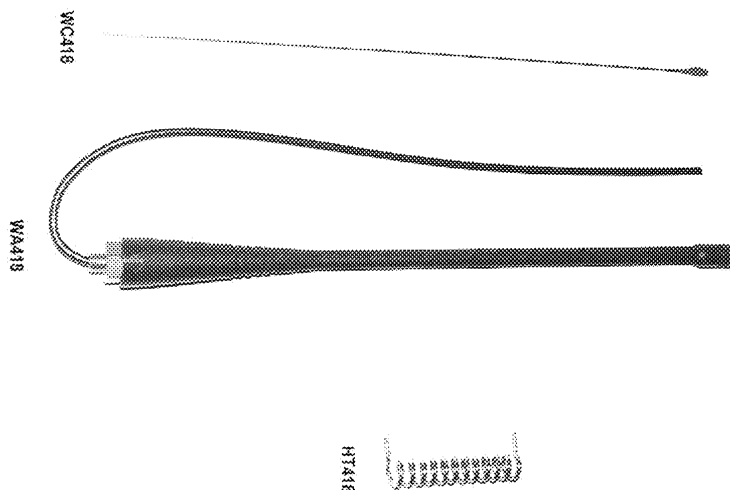

BLANK

BLANK



GLOLAB

CORPORATION

307 Pine Ridge Drive
Wappingers Falls, NY 12590
(845) 297-9771
Fax - (845) 297-9772
Email - lab@glolab.com
<http://www.glolab.com>
© 2007 Glolab Corp.